

RESEARCH

Open Access



Learning principles of accounting in ICT-supported learning environments of Malaysian secondary schools: future-oriented approach

Boon See Tan* and Su Luan Wong

* Correspondence: bstan_29@yahoo.com
Faculty of Educational Studies,
Universiti Putra Malaysia, 43400
Serdang, Selangor, Malaysia

Abstract

This research was undertaken to identify the learning approaches used by Malaysian secondary school students of Principles of Accounting in the context of ICT-supported learning environments. The revised Two-Factor version of the Learning Process Questionnaire (R-LPQ-2F) was adapted to appraise the learning approaches used, while the Technology-Rich Outcomes-Focused Learning Environment Inventory (TROFLEI) was adapted to obtain the perceptions of students in ICT-supported learning environments which practising the ICT-pedagogy. The sample for the study comprised 371 Form Four Malaysian students. There were indications from this study that students employed the deep approach to learning Principles of Accounting; whereas the surface approach was not discernible. Only two scales measured the sub constructs of surface motive and surface strategy, namely aim for qualification and minimising scope of study merged and evolved into what is referred to as the future-oriented approach in this study. Aiming for qualification as a motive is complemented by a non-surface learning strategy of non-minimisation of scope of study, i.e. learning beyond the minimum scope. The future-oriented approach was influenced by socio-cultural and educational contextual factors in Malaysia. The findings also reflected the influence of ICT-supported learning environment perceptions on learning approaches.

Keywords: Students' approaches to learning, Deep approach, Surface approach, Future-oriented approach, ICT-supported learning environment perceptions, Principles of accounting

Introduction

Introductory Accounting is the first stage in accounting education. Students learn how to identify and handle financial information through the application of the double-entry book-keeping system. Introductory Accounting introduces students to the procedures for categorising, recording, summarising, and interpreting financial data. In the Malaysian education system, formal Introductory Accounting is taught at the upper secondary school level. Subsequently, the fundamentals of accounting knowledge and skills are delivered through a subject called Principles of Accounting (Technical Education Department, 2000).

An early study by Marton and Säljö (1976) showed two qualitative differences in learning approaches. The surface approach represents learning through memorising to meet the minimum requirement in assessment, while the deep approach stresses the importance of understanding the meaning of the content and relating it to other experiences and ideas in the learning process (Marton & Säljö, 1984). The deep approach to learning is especially important in the study of accounting, particularly book-keeping, as most concepts must be mastered through understanding the subject and not merely memorising the material (Borthick & Clark, 1986; Jackling, 2005; Sukumaran, 1991; *The Purpose of Accounting Education*, 2016). For example, the concept of double-entry, which involves the elements of debit and credit, cannot be learnt by memorising items that need to be debited or credited. Considerable thinking is required as the student needs to learn how to relate the effects of each business transaction on the accounting equation before deciding whether to apply the procedure of debiting or crediting. Moreover, book-keeping is conducted through a process called accounting cycle, which involves a set of steps in preparing the financial statements for a given period. These steps include recording business transactions in journals based on business documents, posting journal entries to ledgers, examining the accuracy of recording (i.e. debits equal credits) with trial balance, making adjustment entries and preparing adjusted trial balance, preparing financial statements, and closing temporary accounts. As all these steps are inter-linked, one must engage a deep approach to learning in order to master the whole set of accounts throughout the accounting cycle rather than fragmentally studying each accounting process. As emphasised by Borthick and Clark (1986), learning accounting should not be dominated by procedural rules. Students need to understand the general principles or underlying concepts to organise all the steps and procedures into a coherent whole.

The use of ICT in the teaching and learning of accounting is aimed at enhancing students' deep approach to learning. Students will strengthen their ability to connect what they have been taught with situations at the computerised workplace and real life, improve social interactions and realise personalisation in learning, thus increasing the effectiveness of teaching and learning (Arquero & Romero-Frias, 2013; Jebeile & Abeyssekera, 2010; Turner, 2011).

However, many researchers observe that, in reality, students always perceive accounting as being technical or procedure-oriented, and that learning accountancy is simply learning a set of rules. Hence, they tend to adopt a surface learning approach compared to students of other subjects (Booth, Lockett, & Mladenovic, 1999; Dull, Schleifer, & McMillan, 2015; Duman, Apak, Yucenursen, & Peker, 2014; Eley, 1992; Lucas, 2000; Sharma, 1997). For example, when learning to prepare a balance sheet, some students tend to follow the required format and try to fit the items and figures in by perceiving the balance sheet as a collection of fragmented data rather than seeking the meaning and significance of the financial statement.

Therefore, this study was conducted to investigate the approaches used by Malaysian students who are taught Principles of Accounting in learning environments that are supported by ICT. The findings obtained from this study would yield vital information to both teachers and students so that they can meet the challenges of

using technology to more effectively in the classroom, especially with regard to the subject, Principles of Accounting.

Literature review

Students' Approaches to Learning (SAL)

Swedish researchers Marton and Säljö (1984) made significant contributions to student learning research by first proposing the concept of "approach to learning". They investigated how students perceived a particular reading task before starting to read. While theirs was a qualitative study, Biggs (1993, 1987a) carried out a quantitative research on surface and deep learning approaches to learning. He discovered a third learning approach, namely the achieving approach, the result of "institutional demands" (Biggs, 1993). Students adopt this approach in the hope of getting higher grades by using organised study methods and practising good time management. Each approach consists of two elements, namely "motive" and "strategy"; the former explains why students want to adopt certain approaches to learning task while the latter explains how they execute the chosen approach. For instance, the deep learning approach incorporates a "motive" to learn in a particular way and a "strategy" to handle the learning task at hand. If the motive is to discover meaning, a deep motive, he or she would adopt a deep strategy to extract the maximum meaning by attempting to fully understand the content.

However, in recent research on learning approaches, the three approaches mentioned above have been merged into two. According to Biggs and Moore (1993), the achieving approach may be associated with either the surface or deep approach as it is more focused on how learners organise their time and techniques to engage with the task at hand, in other words, a learner can either adopt a deep or surface learning approach in an organised or disorganised way.

Delving further into the above studies on learning approaches, Biggs, Kember, and Leung (2001) and Kember, Biggs, and Leung (2004) employed confirmatory factor analysis to validate the instruments of the revised Study Process Questionnaire (SPQ) (Biggs, 1987b) and the Learning Process Questionnaire (LPQ) (Biggs, 1987c) using a student sample from Hong Kong. They found that the two-factor model which consisted of deep and surface approaches had a better fit than the previous three-factor solution (surface, deep, and achieving approaches) of the original SPQ and LPQ. With the results of these studies yielding good reliability values with reasonable goodness-of-fit values, both the SPQ and LPQ instruments were further revised to a shorter version named "Revised Two-Factor version of the SPQ" (R-SPQ-2F) and "Revised Two-Factor version of the LPQ" (R-LPQ-2F) respectively. These instruments also validated the two sub constructs of "motive" and "strategy" for both surface and deep approaches, and a two second-order factor model for both approaches was thus derived.

Immekus and Imbrie's (2010) cross-cultural research studied the R-SPQ-2F instrument (Biggs et al., 2001) through data collected from undergraduates in the United States. When the factor analytic results revealed that the two-factor structure was cross-culturally sensitive, an alternative four-factor model of the item-level data encompassing deep motive, deep strategy, surface motive, and surface strategy was suggested. The authors claimed that the differences in results might be due to the distinct approaches that Hong Kong and United States students employed in their learning.

Fryer, Ginns, Walker, and Nakao (2012) conducted the Students' Approaches to Learning (SAL) study in the Japanese tertiary education context. Based on the confirmatory factor analysis, the results showed that items measuring surface approach did not perform well. As pointed out by the respondents in a qualitative pilot study, some of the surface approach items did not clearly reflect the approach. In addition, a moderate positive relationship between surface and deep approaches was observed. This contrasted strongly with previous studies which always showed a negative relationship between the two approaches. An item parcel-based two-factor model of deep and surface approach was, therefore, obtained as a result without the sub constructs for "motive" and "strategy". The results suggest that the SAL constructs may be constituted differently in the Japanese culture.

Malaysian university students' learning approaches were examined by Wan Shahrazad Wan Sulaiman, Wan Rafaei Abdul Rahman, Mariam Adawiah Dzulkifli, and Wan Samhanin Wan Sulaiman (2013). The confirmatory factor analysis reported a good fit of the two-factor model of deep approach and surface approach without the sub constructs for "motive" and "strategy" after removing several items. Similar to the findings of Fryer et al. (2012), the study reported a moderate positive relationship between both approaches, probably reflecting the cultural influence in the Malaysian context.

Martinelli and Raykov (2017) conducted SAL research using student teachers in Malta to determine the feasibility of applying the R-SPQ-2F instrument (Biggs et al., 2001) to diagnose and monitor their approaches to learning. The results showed that both deep and surface approaches demonstrated acceptable internal consistency, but the sub constructs of both approaches had relatively low internal consistency. The results were consistent with the findings by Fryer et al. (2012) and Wan Shahrazad Wan Sulaiman et al. (2013), i.e. they supported the existence of deep and surface approaches, but the sub constructs had yet to be further validated.

Taken as a whole, the SAL theory has long been studied by various researchers through both qualitative and quantitative methods. It delineates the distinction between the deep and surface approaches to learning. The former is synonymous with effective and desirable attitudes to learning while the latter approach is thought to promote undesirable attitudes to learning. The focus in this study is only on the deep and surface approaches as the achieving approach can be related to either of these approaches. In more recent research on SAL, the sub constructs of "motive" and "strategy" were validated by Immekus and Imbrie (2010), while many could only prove the validity of the two-factor model (Fryer et al., 2012; Martinelli & Raykov, 2017; Wan Shahrazad Wan Sulaiman et al., 2013). While deep and surface approaches are found to have negative relationships in most of the studies, Fryer et al. (2012) and Wan Shahrazad Wan Sulaiman et al. (2013) reported a unique moderately positive relationship between the two. All the aforesaid findings on the two-factor model reflect cultural sensitivity in SAL research.

The Presage-Process-Product Models

In order to understand better why students learn and act differently during the learning process, and to link learning theories to practices, Biggs (1985) introduced the Presage-Process-Product (3Ps) Model, which is shown in Fig. 1. It provides a theoretical

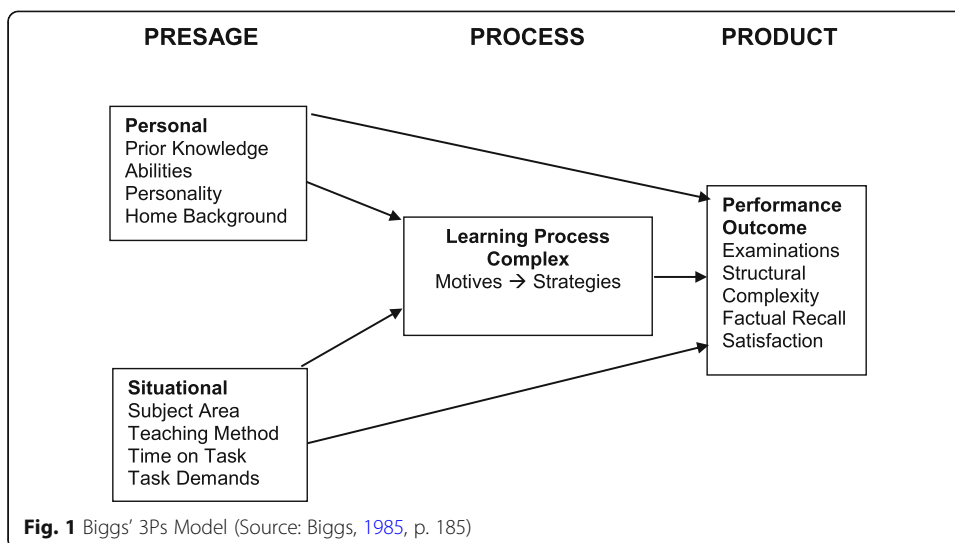

framework for understanding the interrelationships of personal characteristics of individual students, teaching contexts, learning approaches, and learning outcomes. In addition, it exhibits a system approach to learning, illustrating how a learner experiences learning through three distinct stages, viz. presage, process, and product. Presage is the stage before learning takes place, which includes students' internal and external factors represented by personal and situational factors respectively that exist in the learning context; process is the stage during which learning takes place, which is represented by students' approaches to learning; product is the learning outcome after learning has taken place.

At the presage stage, the variables include students' personal factors such as their prior knowledge of a learning subject, abilities, personality, and home background; while situational factors in a learning context consist of variables such as subject areas, teaching methods, time spent on a task, task demands, and course structures. Each factor has a direct effect on performance and is also likely to affect students' motives and perceptions of a task and the strategies adopted in learning.

The process stage, on the other hand, refers to the complex learning process which involves students' learning motives and strategies. Biggs (1985) explains that this stage of learning represents the way students perceive the academic environment, and based on that perception, a suitable learning approach is adopted to tackle the learning task with consequent effects on performance. In other words, students' approaches to learning are malleable, representing a choice of their learning behaviours that are consistent with their perceptions of the learning environment (Biggs, 1993, 1999).

Ramsden (2003) further expands the 3Ps Model proposed by Biggs (1985) by highlighting students' perceptions of task requirements (illustrated in Fig. 2). According to the author, between receiving instructions and the learning process lie the learner's perceptions of the learning context or the general learning environment; subsequently, the learner will decide what the task requires. In this context, Ramsden (2003) stresses the importance of good teaching to enable students achieve quality learning outcomes. By providing a supportive learning environment, one that encourages active participation and provides quality feedback, students would have a more positive perception of the learning task. Students' perceptions of task requirements, or the perceptions of the

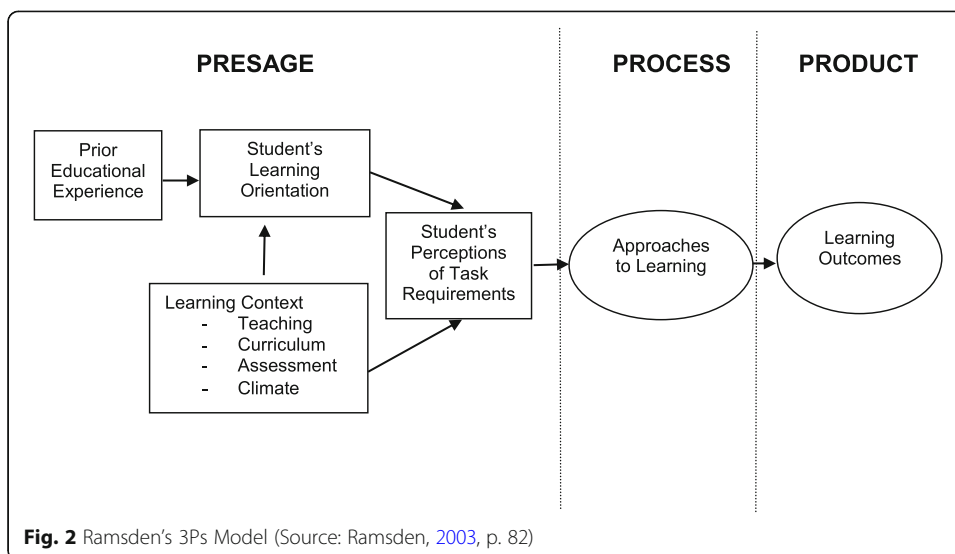

learning environment include their perceptions of teaching support, curriculum, assessment, and class climate. Ultimately, this is the deciding situational factor that influences approaches to learning and learning outcomes.

Learners' perceptions are also simultaneously influenced by personal characteristics of their learning orientation. These in turn, affect their approach to learning and learning outcomes. Thus, the author proposed that to improve the quality of students' approaches to learning, their perceptions of the learning context have to be determined, as part of the presage factors of the 3Ps Model.

Taken together, both Biggs (1985)'s and Ramsden (2003)'s 3Ps Models describe learning outcomes as consequences of the interaction between students' characteristics and the learning context during the learning process. The learning approach, in turn, mediates the outcomes achieved.

Kozma (1991) stresses that, in an ICT-supported learning environment, the media or technology characteristics interact with task characteristics, together with the characteristics of individual learners, to influence the learning process. This notion is consistent with the 3Ps Models where ICT stands as an important presage factor which interacts with other aspects of the situational factors or learning context (e.g. teaching, assessment, peer, curriculum), as well as personal factors of students to influence students' choice of learning approaches. Against this backdrop, the application of an ICT-pedagogy enables a student-centred learning environment where the teacher's role has changed from instructor to constructivist (Harada, 2003). The teacher creates platforms for students to be actively involved in the learning process, such as providing technology-rich learning environments for easy access to learning materials, online assessments, and communication with teacher and peers (Prensky, 2001), thus, enabling students to build upon existing knowledge structures and facilitate them to interact freely with information. Hence, the application of an ICT-pedagogy helps develop a learning environment that is interactive, collaborative, and supportive. In this study, students' various perceptions of such a learning environment are referred to as the ICT-supported learning environment perceptions (ISLEP).

Methodology

As the present research was aimed at investigating the influence of Malaysian secondary school students' perceptions of an ICT-supported learning environment on their approaches to learning Principles of Accounting, the correlational research design was used. An ICT-supported learning environment covers the use of generic software (e.g. word processing, spreadsheet), on-line information and communication tools (e.g. email, blog, forum, portal), and search engines (e.g. Google) in teaching and learning. Students use ICT to complete and submit assignments, search information, obtain notes, and conduct on-line discussion and communication with the teacher and peers (Aldridge, Dorman, & Fraser, 2004).

Participants

The respondents of this study were Form Four (equivalent to Grade 10 in the United States) Malaysian students who were studying Principles of Accounting in an ICT-supported learning environment. Three types of schools were targeted in this study, namely Smart Schools (Smart School Project Team, 1997), schools that built a Principles of Accounting blog, and schools that engaged in simulated virtual business and entrepreneurship programmes. As many challenges have been reported in the utilisation and integration of ICT in teaching and learning where teachers in Malaysia seldom take full advantage of the ICT facilities (Nadzrah Abu Bakar, 2007; Ministry of Education, 2006; United Nations Educational, Science and Cultural Organization, 2012, 2015), the present study has to identify schools which actively utilise and integrate ICT. The aforesaid three types of school provided ICT-supported learning environments as defined by Aldridge et al. (2004).

To ensure the findings were representative and could be generalised, the researcher applied multistage proportional stratified cluster sampling in randomly selected states representing five major regions of Malaysia (Tourism Malaysia, 2013), namely Kedah (Northern Region), Selangor (Central Region), Johore (Southern Region), Kelantan (East Coast Region), and Sabah (East Malaysia). The sample consisted of 371 participants. The questionnaires were administered by the researcher via a face-to-face survey to ensure authenticity of the data elicited and also to obtain a high response rate.

Instruments

Students' Approaches to Learning

The instrument used to assess Students' Approaches to Learning (SAL) for this study was adopted and adapted with permission from the Revised Two-Factor version of the Learning Process Questionnaire (R-LPQ-2F) developed by Kember et al. (2004). This instrument was chosen as it is specially designed to measure the learning approaches of secondary school students, unlike Biggs' (1987b) Study Process Questionnaire which assesses the learning approaches of university students. Furthermore, the R-LPQ-2F is a simplified version consisting of only the deep and surface approach scales measured by a reasonably small number of items. It is, thus, suitable for use by secondary school students.

The modified instrument in this study comprised 25 items, where both deep and surface approaches were measured by 13 and 12 items respectively. The construct of each

learning approach was further measured by the sub constructs of motive and strategy. In other words, the deep approach consisted of deep motive and deep strategy, while the surface approach comprised surface motive and surface strategy. Each sub construct was further measured by two scales where deep motive contained the scales of intrinsic interest (II) and commitment to work (CW); deep strategy was measured by scales of relating ideas (RI) and understanding (Ud). On the other hand, surface motive consisted of the scales of fear of failure (Fr) and aim for qualification (Qlf); surface strategy was indicated by scales of minimising the scope of study (Scp) and memorisation (Mm). Sample items are listed in Table 1 below.

All the items of the instrument were designed to be rated by the respondents using a five-point Likert scale, ranging from “Never” to “Almost Always” (other options being “Seldom”, “Sometimes”, “Often”). These responses were scored as follows: “Never”-1 point; “Seldom”-2 points; “Sometimes”-3 points; “Often”-4 points; and “Almost Always”-5 points.

ICT-supported learning environment perceptions

Since Aldridge et al.’s (2004) definition of ICT-supported learning environment was adopted for the present study, it was appropriate to employ the instrument designed by these researchers to investigate Malaysian students’ perceptions of ICT-supported learning environments. The Technology-Rich Outcomes-Focused Learning Environment Inventory (TROFLEI) designed by Aldridge et al. (2004) was, thus, adopted and adapted with permission. Moreover, TROFLEI was used for this study as it focuses on assessing secondary school students’ perceptions of learning environments where ICT-pedagogy is the norm. The modified instrument in this study consisted of seven scales measured by 55 items that assessed students’ perceptions of ICT usage (ICT), student cohesiveness (SC), teacher support (TS), cooperation (CO), involvement (IVL),

Table 1 Structure and sample items in the adapted R-LPQ-2F instrument

Approach	Total item	Sub construct	Scales	Sample item
Deep approach	13	Deep motive	Intrinsic interest	I find that at times studying Principles of Accounting makes me feel really happy and satisfied.
			Commitment to work	I like to do enough work on a topic of Principles of Accounting so that I can fully master its concepts.
		Deep strategy	Relating ideas	I try to relate what I have learned in Principles of Accounting to what I have learned in other subjects.
			Understanding	When I read a Principles of Accounting textbook, I try to understand its contents.
Surface approach	12	Surface motive	Fear of failure	I am discouraged by a poor mark on a test of Principles of Accounting.
			Aim for qualification	I intend to pursue an accounting degree because I feel that I will then be able to get a better job.
		Surface strategy	Minimising scope of study	I learn only topics which are included in the examination of Principles of Accounting.
			Memorisation	I learn Principles of Accounting by rote, going over and over them until I know them by heart.

Table 2 Structure and sample items in the adapted TROFLEI instrument

Scales	Sample Item
ICT usage	I use the computer to type my assignments for Principles of Accounting.
Student cohesiveness	In the learning environment which is supported by ICT, I work well with other students in this class.
Teacher support	In the learning environment which is supported by ICT, the Principles of Accounting teacher in this class takes a personal interest in me.
Cooperation	In the learning environment which is supported by ICT, I cooperate with other students in this class, when doing accounting exercises.
Involvement	In the learning environment which is supported by ICT, I discuss ideas in this class.
Investigation	In the learning environment which is supported by ICT, I carry out investigations to test my ideas.
Task orientation	In the learning environment which is supported by ICT, getting a certain amount of accounting work done is important to me in this class.

investigation (IVG), and task orientation (TO). In this context, ICT usage included perceptions of using various ICT tools such as generic software, on-line information and communication tools, search engines for teaching and learning as defined by Aldridge et al. (2004). Sample items of TROFLEI are listed in Table 2 above.

Each of these scales was measured by a five-point Likert scale, ranging from “Never” to “Almost Always” (“Never”, “Seldom”, “Sometimes”, “Often” and “Almost Always”). These responses were scored as follows: “Never”-1 point; “Seldom”-2 points; “Sometimes”-3 points; “Often”-4 points; and “Almost Always”-5 points.

Personal factors

Based on the 3Ps models proposed by Biggs (1985) and Ramsden (2003), students’ approaches to learning and perceptions are also influenced by their personal factors. Thus, personal factors such as academic ability and prior educational experience were included in the research framework of the current study as they were important factors in determining learning (Bloom, 1976).

The respondents’ academic ability was assessed through their grades obtained for mathematics, science, and the Malay language in the Lower Secondary Summative Assessment. Prior educational experience refers to the respondents’ accounting knowledge, previous experience of doing business or being an entrepreneur in the family, school, work, or participation in self-organised entrepreneurial activities. According to entrepreneur education researchers, a person learns about business through formal education and training, experience, and vicarious experience obtained from his or her environment such as family, school or working place (Holcomb, Ireland, Holmes, & Hitt, 2009; Pittaway & Cope, 2007).

Pilot study

The adapted R-LPQ-2F and TROFLEI instruments were pilot-tested prior to the actual data collection to assess their appropriateness in terms of reliability and construct validity. Pilot-testing was conducted in two schools which fulfilled the criteria of ICT-supported learning environment; 90 students participated in the pilot study.

Table 3 Reliability of the instruments in pilot test ($N = 90$)

Scale	Cronbach's alpha
Deep approach	.84
Deep motive	.78
Deep strategy	.72
Surface approach	.72
Surface motive	.70
Surface strategy	.69
ICT-supported learning environment perceptions	
ICT usage	.88
Student cohesiveness	.85
Teacher support	.90
Cooperation	.93
Involvement	.88
Investigation	.87
Task orientation	.91

The reliability values are presented in Table 3 where values for all the scales ranged from .69 to .93. The results indicated that the instruments had satisfactory internal consistency as all the reliability values were near to or higher than .70 (DeVellis, 2003).

To establish construct validity, an exploratory factor analysis (EFA) was conducted to assess the possible underlying factor structure without imposing a preconceived structure on the outcome (Child, 1990). Meanwhile, a confirmatory factor analysis (CFA) was further conducted on the actual data to determine the ability of a predefined factor model to fit an observed set of data (DeCoster, 1998). In this case, both analyses were tested on a different sets of data to evaluate construct validity. According to DeCoster (1998), if the findings of an EFA are put directly into a CFA on the same data, the procedure is like merely fitting the data and not testing theoretical constructs. Thus, the pilot data were used for EFA, while the actual data, another set of data for theoretical construct testing, were used for CFA in the present study.

The factorability of the deep approach items was first examined through EFA. By using methods of principal components analysis with promax rotation, four factors of deep approach were extracted (Table 4). They were the scales measuring intrinsic interest (II), commitment to work (CW), relating ideas (RI) and understanding (Ud), with almost all items grouped under an individual factor or scale according to the SAL theory. In addition, the communalities were all above .3, confirming that each item shared some common variance with other items.

Though item C22 cross-loaded on two factors with both factor loading values less than .5, the item had moderately high communality of .65. According to Costello and Osborne (2005), only item with communality of less than .4 has to be removed as it may either not be associated with other items or may suggest that an additional factor should be explored. In this study, this item was retained for further verification in the confirmatory factor analysis. Overall, all the 13 items were retained after performing EFA.

On the other hand, the factorability of the surface approach items was also assessed. Table 5 shows four factors measuring surface approach were also extracted according to the SAL theory. These factors were fear of failure (Fr), aim for qualification (Qlf),

Table 4 Factor loadings and communalities for 13 items measuring deep approach ($N = 90$)

Code	II	CW	RI	Ud	Communality
C1	.95				.78
C6	.76				.68
C10	.72				.63
C14		.78			.62
C18		.55			.45
C20		.85			.61
C22	.43	.48			.65
C2			.87		.85
C7		.47			.45
C24			.79		.59
C11				.64	.51
C15				.51	.49
C25				.91	.73

II intrinsic interest, CW commitment to work, RI relating ideas, Ud understanding

Note: factor loadings < .4 are suppressed

minimising scope of study (Scp), and memorisation (Mm). All these items had communalities values above .3, indicating that each item shared some common variance with other items. Though item C5, C19, and C23 cross-loaded on two factors, according to Lirn, Lin, and Shang (2014), the loading on the factor with factor loading less than .5 will be ignored and the item loaded with higher loading should be considered as an indicator of the factor. As a result, all the 12 items measuring surface approach were retained after performing EFA for further verification through CFA in actual study.

The results of the EFA for the construct of ICT-supported learning environment perceptions are shown in Table 6. It is obvious that each item shared some common variance with other items as the communalities were all above .3. Seven factors were extracted where almost all the items clustered back to their respective factor or scales, according to the original TROFLEI instrument. These factors or scales were ICT usage (ICT), student cohesiveness

Table 5 Factor loadings and communalities for 12 items measuring surface approach ($N = 90$)

Code	Fr	Qlf	Scp	Mm	Communality
C3	.87				.78
C4	.85				.74
C8	.68				.54
C12		.82			.74
C16		.77			.66
C5			.50	.41	.39
C9			.68		.60
C13			.80		.69
C17			.68		.49
C19	.43			.76	.63
C21				.76	.72
C23	.48			.66	.57

Fr fear of failure, Qlf aim for qualification, Scp minimizing scope of study, Mm memorisation

Note: factor loadings < .4 are suppressed

Table 6 Factor loadings and communalities for 55 items measuring ICT-supported learning environment perceptions ($N = 90$)

Code	ICT	SC	TS	CO	IVL	IVG	TO	Communality
ICT1	.57							.73
ICT2	.69							.70
ICT3	.51							.68
ICT4	.80							.79
ICT5	.81							.73
ICT6	.86							.70
ICT7	.65							.64
ICT8	.82							.76
SC1		.68						.79
SC2		.75						.65
SC3		.63						.78
SC4		.81						.81
SC5		.87						.82
SC6		.75						.66
SC7		.60						.77
SC8		.82						.75
TS1			.78					.69
TS2			.92					.80
TS3			.85					.77
TS4			.87					.85
TS5			.81					.84
TS6			.63					.78
TS7			.68					.76
TS8			.64					.80
CO1				.80				.82
CO2				.91				.77
CO3				.72				.75
CO4				.64				.74
CO5				.71				.81
CO6				.65				.81
CO7				.68				.82
CO8				.61				.85
IVL1		.41			.65			.79
IVL2					.75			.76
IVL3					.73			.81
IVL4					.81			.80
IVL5					.70			.82
IVL6					.81			.76
IVL7					.75			.80
IVL8					.67			.78
IVG1						.91		.80
IVG2						.86		.84
IVG3						.61		.69

Table 6 Factor loadings and communalities for 55 items measuring ICT-supported learning environment perceptions ($N = 90$) (Continued)

Code	ICT	SC	TS	CO	IVL	IVG	TO	Communality
IVG4						.66		.73
IVG5						.51		.74
IVG6						.71		.76
IVG7						.85		.83
TO1							.79	.76
TO2							.81	.81
TO3							.70	.73
TO4							.77	.77
TO5							.78	.77
TO6							.71	.84
TO7							.72	.81
TO8							.86	.77

ICT ICT usage, SC student cohesiveness, TS teacher support, CO cooperation, IVL involvement, IVG investigation, TO task orientation

Note: factor loadings < .4 are suppressed

(SC), teacher support (TS), cooperation (CO), involvement (IVL), investigation (IVG) and task orientation (TO).

Though item IVL1 cross-loaded on two factors, the lower factor loading which was less than .5 (.41) could be ignored (Lirn et al., 2014). Consequently, 55 items were retained after EFA and were further verified through CFA in the actual study.

Overall, EFA established the construct validity of the two instruments for this research, namely R-LPQ-2F and TROFLEI before they were used in the actual study. All the measuring items were retained after their analysis showed high construct validity of the instruments.

Data analysis

A confirmatory factor analysis was further conducted on the actual data to determine the ability of a predefined factor model to fit an observed set of data (DeCoster, 1998). Structural equation modelling (SEM) was subsequently performed to analyse the relationships of ICT-supported learning environment perceptions, academic ability, and prior educational experience on students' approaches to learning. As the present study consisted of two dependent variables, viz. deep approach and surface approach, the use of SEM was more appropriate compared to multiple regression which can accommodate only one dependent variable (Hair, Black, Babin, Anderson, & Tatham, 2006).

Results

Students' Approaches to Learning

The confirmatory factor analysis validated the hierarchical structure of deep approach which, according to the SAL theory, is formed by the sub constructs of deep motive and deep strategy (Fig. 3). In this regard, the deep motive and deep strategy are formed by item parcels. Item parcel is an aggregate-level indicator comprising the sum (or average) of two or more items (Little, Cunningham, Shahar, & Widaman, 2002).

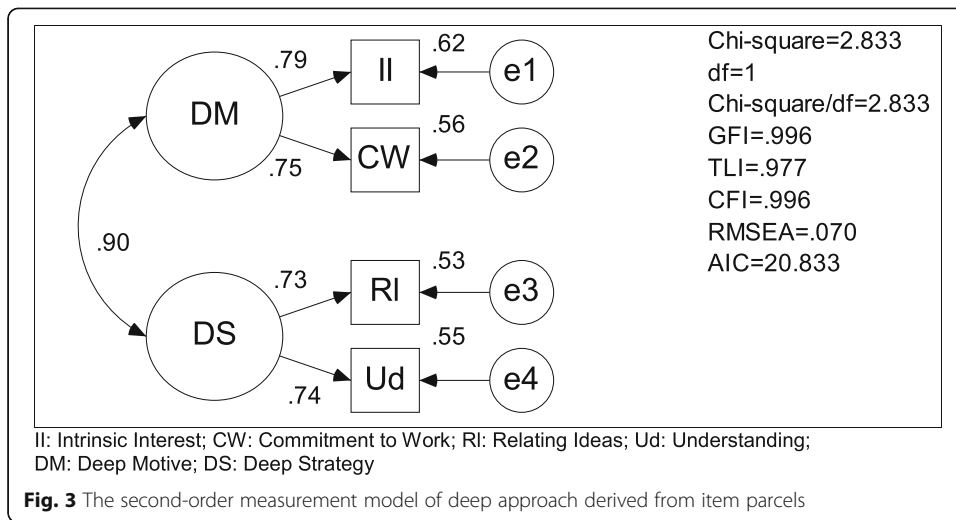

According to MacCallum, Widaman, Zhang, and Hong (1999), compared with item-level data, models based on parcelled data have fewer indicators, and are thus more parsimonious, having fewer opportunities for residuals to be correlated and are able to lead to reductions in various sources of sampling error. Hence, parcelled-based models could produce a more stable solution for model fit.

The surface approach, however, was not discerned in the current learning context. The scales of memorisation (Mm) and fear of failure (Fr) which measured surface approach were removed from the model. The former was due to all its items (C19, C21, and C23) having poor correlation (below the .30 minimum criterion) with other items

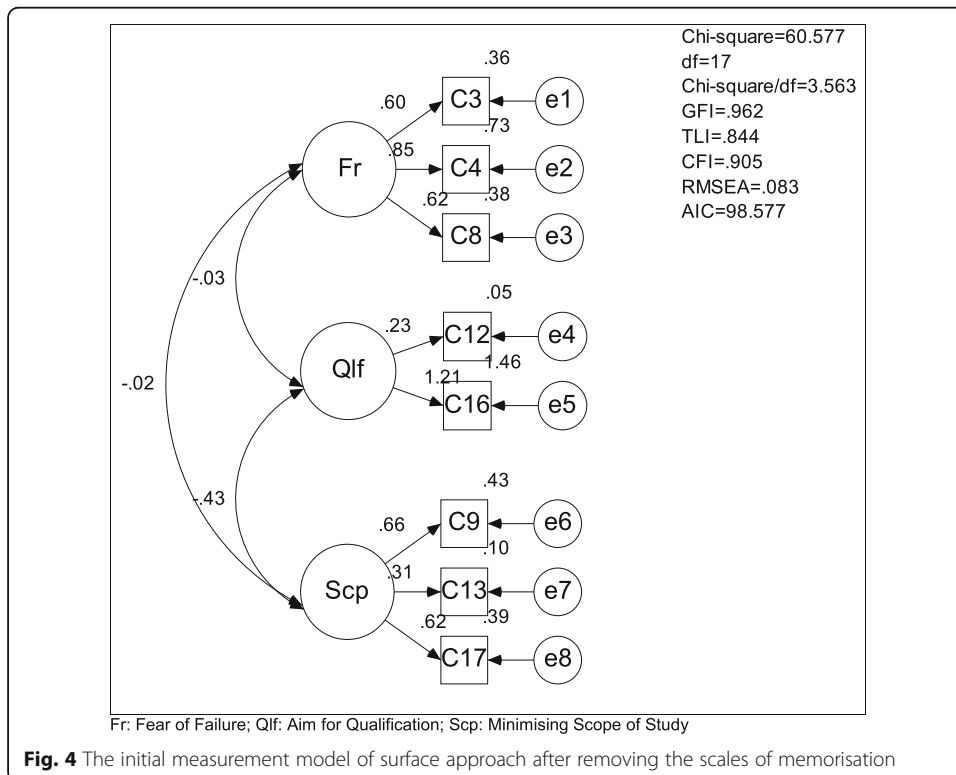

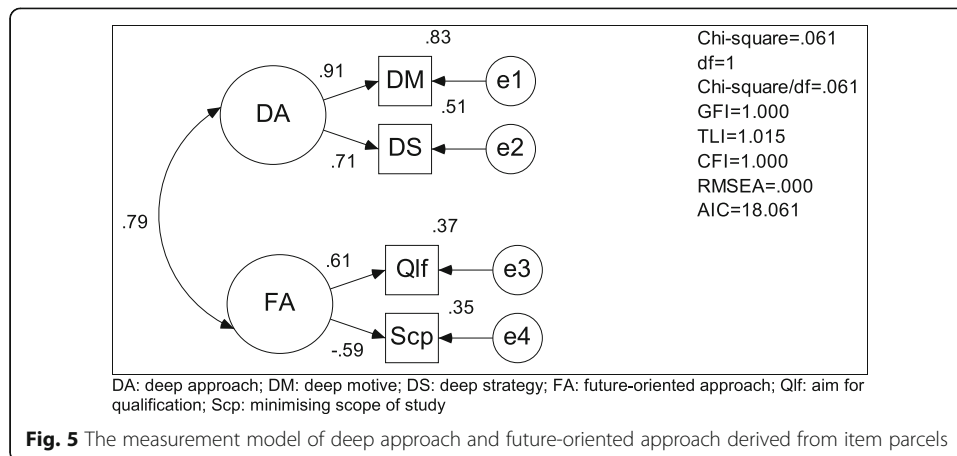

measuring surface approach, while the latter did not correlate well with both the scales, aim for qualification (Qlf) ($r = -.03$) and minimising scope of study (Scp) ($r = -.02$) to measure surface approach (Fig. 4).

The final model of surface approach (Fig. 5) presents both of its scales, with Qlf and Scp merging as one and having high correlation with deep approach (DA) ($r = .79$). As such, it is a new learning approach, referred to as the future-oriented approach (FA) in this study. Scp that measured the learning strategy was negatively related to Qlf, which measured for learning motive. In other words, instead of minimising scope of study, the reverse of Scp could denote a non-surface strategy that was related to Qlf, the learning motive which aims for qualification. The result, thus suggested that for the sake of achieving a good qualification in the future, students did not limit their scope of study. Hence, this construct was also related to the deep approach but especially concern on the learning behaviour which is driven to study with a focus on the future, in particular to obtain a desirable qualification (Liem, Nair, Bernardo, & Prasetya, 2008). The construct was different from the surface approach as it did not relate significantly with the scales of fear of failure (Fr) and memorisation (Mm). It was an emerging construct which could be influenced by the local social norms and educational culture. In addition, the removal of the scale of memorisation (Mm) could be attributed to students' perceptions that the strategy of memorisation was not applicable to the learning of Principles of Accounting. Indeed, the learning of accounting requires a reasoning approach rather than mechanically learning it through memorisation (Borthick & Clark, 1986; Jackling, 2005; Sukumaran, 1991; The Purpose of Accounting Education, 2016).

On the other hand, the construct of deep approach (DA) was formed by the item parcels of deep motive (DM) and deep strategy (DS) as the initial hierarchical structure of DA did not meet the assumption of multivariate normality. Thus, it was necessary to revise it by converting the sub constructs of DM and DS into item parcels.

ICT-supported learning environment perceptions

The final measurement model of ICT-supported learning environment perceptions (ISLEP) was validated by the confirmatory factor analysis is as shown in Fig. 6. The model suggested that student cohesiveness (SC), cooperation (CO), and investigation (IVG) were interrelated; while teacher support (TS) and involvement (IVL) should be

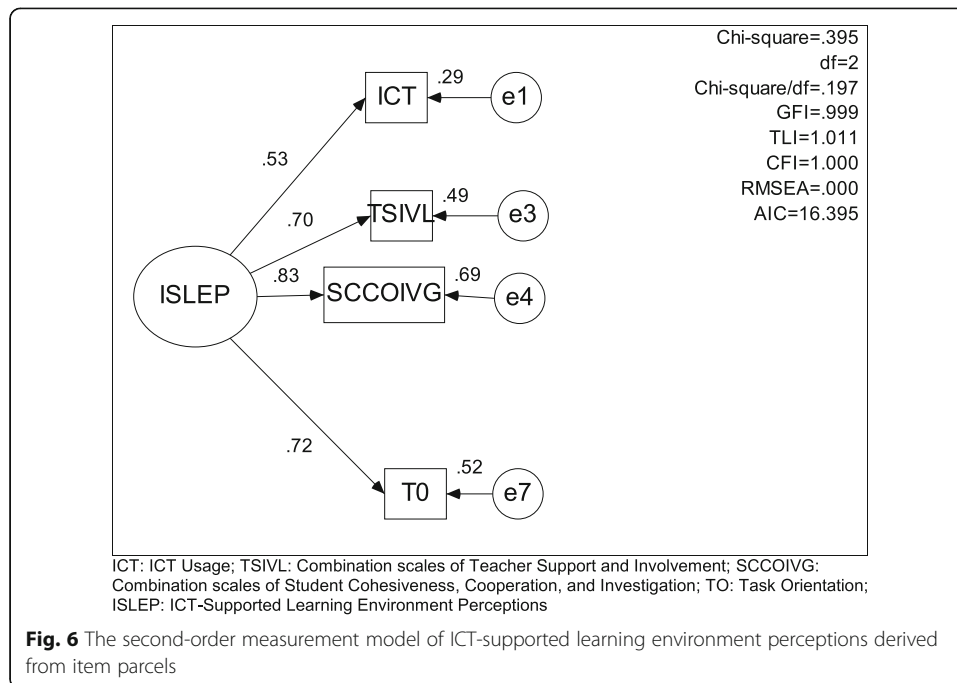

also merged as one. The combination of SC, CO, and IVG was possible as students used to have group investigation activities (Sharan, 1995) during classes and, thus, cooperation was inter-connected with investigation. Group investigation is a cooperative learning strategy involving task specialisation; students work in small groups to investigate a specific topic (Slavin, 1995). Sharan and Sharan (1992) emphasise that group investigation is dependent on student interaction and thus, cohesiveness among students is the catalyst to facilitate interaction. Student cohesiveness, in turn, is also enhanced in the process of the group investigation. Therefore, the three sub constructs of SC, CO, and IVG could be interrelated and combined as one.

Similarly, the intercorrelatedness of TS and IVL can be explained by the Attachment Theory which states that students use their positive relationships with adults to organise their experiences (Ainsworth & Bowlby, 1991). Central to this theory is that students with close relationships with their teachers view them as a “secure base” from which to explore their learning environment. Many studies have found that positive teacher-student relationships encourage students to be more involved in the learning process (Buhs, Ladd, & Herald, 2006; Hamre & Pianta, 2001; Wentzel, 2004, 2009). Therefore, both sub constructs of TS and IVL were considered interrelated and were grouped as one.

The influence of ICT-supported learning environment perceptions on Students' Approaches to Learning

The structural model in the present study is presented in Fig. 7. The model shows that the construct of ICT-supported learning environment perceptions (ISLEP) had a very significant influence on deep approach to learning (DA) ($\beta = .848, p < .001$) and future-oriented approach to learning (FA) ($\beta = .734, p < .001$). Meanwhile, ISLEP was significantly influenced by

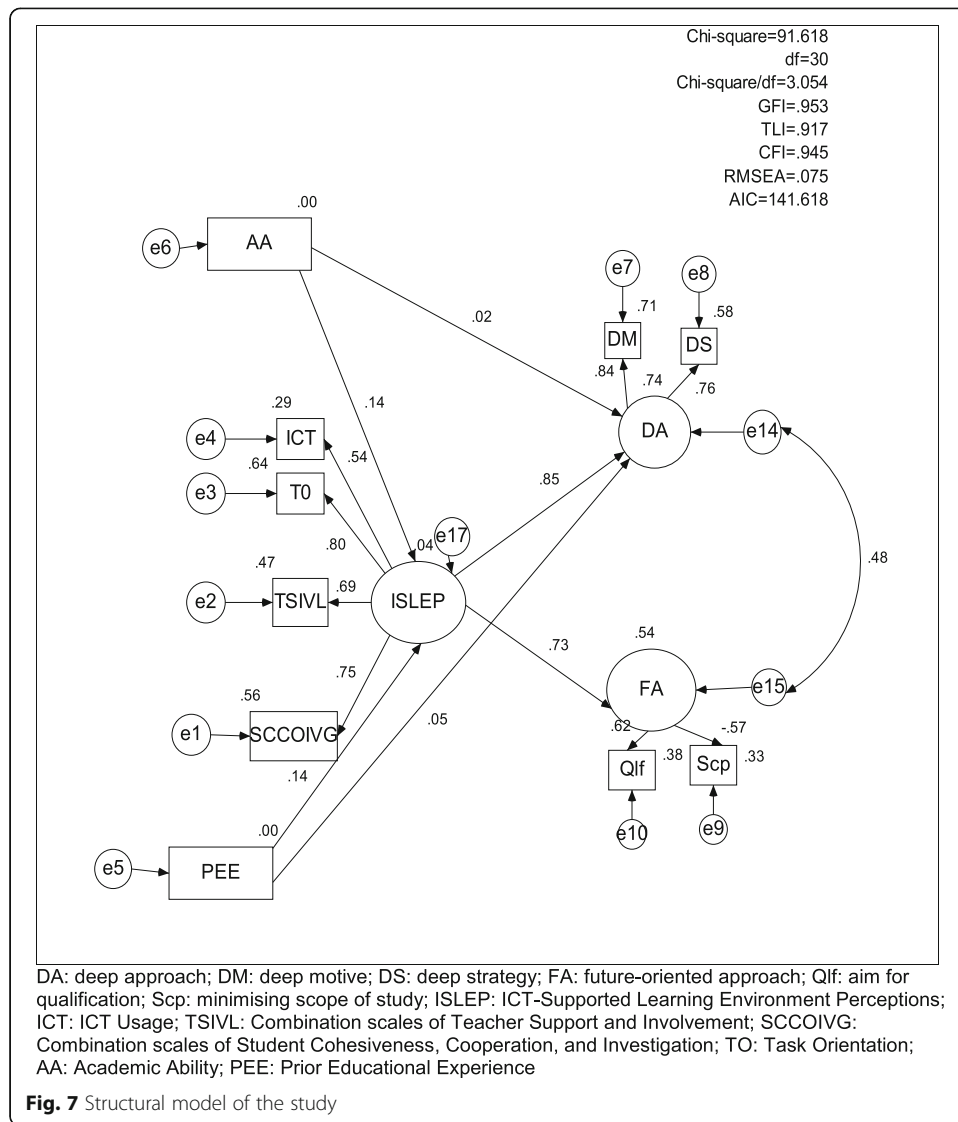

academic ability (AA) ($\beta = .143, p < .05$) and prior educational education (PEE) ($\beta = .140, p < .05$).

Discussion

Deep approach

The deep approach to learning validated in this study explicates the sub constructs of deep motive and deep strategy. The findings prove the generalisability of the propositions of the deep approach according to the SAL theory (Biggs, 1987a, 1993) because Malaysian students also use a similar approach to their learning. The result is also coherent with the findings of Immekus and Imbrie (2010) where the construct of deep approach is validated together with its sub constructs of deep motive and deep strategy. This finding enhances the notion advocated by Richardson (1994) in his literature research of SAL that the relative reliable of the construct of deep approach could be due to the intercultural consensus regarding the purpose of education.

Surface approach and future-oriented approach

The confirmatory factor analysis results in this study indicated that surface approach did not collate according to the multidimensional structure as stated in SAL theory. Thus, the finding is coherent with Fryer et al. (2012) who find that surface approach has generally lower reliability, and is the least culturally portable. In other words, cross-cultural sensitivity is a key point to be considered when conducting SAL studies.

The results further reveal the future-oriented approach to learning emerging as a new learning approach. It consists of the motive of aiming for qualification complemented by the non-surface learning strategy of non-minimisation of scope of study, i.e. learning beyond the minimum scope. It features a unique learning approach which is future-oriented; students put in extra effort to study to secure a better future. This finding echoes the cross-cultural study conducted by Liem et al. (2008) who explored the culture-general (etic) and culture-specific (emic) aspects of learning approaches used by Asian secondary school students, and found that students were driven to aim for brighter job prospects after graduation. Aiming for qualification is originally described by Biggs (Biggs, 1987a, 1993) as extrinsically driven, and therefore has a surface motive. However, it is complemented with a non-surface strategy in the present study. In other words, it is a distinct approach consisting of two incongruent elements, viz. surface motive (aim for qualification) and non-surface strategy (learning beyond the minimum scope of study). Therefore, the future-oriented learning approach contradicts Biggs' (Biggs, 1985, 1987a) notion of meta-learning which states that students have the awareness to adopt a learning strategy that is congruent with their learning motive (e.g. deep strategy derived from deep motive).

Liem et al. (2008) argue that the future-oriented motivation of aiming for qualification should not be categorised as surface motive as defined by Biggs (1987a, 1993), but should instead be categorised as a separate domain of academic motivation which is related to future goals. In contrast, deep motive (intrinsic interest and commitment to work) and surface motive (fear of failure) are concerned with the engagement of a task at hand for a more immediate purpose. Future goals have been studied by researchers to understand students' motivation from the context of future time perspective (DeVolder & Lens, 1982; Simons, Vansteenkiste, & Lens, 2004). Studies have also been conducted to determine how striving to attain future goals may enhance students' engagement, level of information processing, persistence, and academic performance. Miller and Brickman (2004) further advocate that students possess both future and immediate goals to shape learning behaviours. Future goals help students look beyond immediate needs by rendering meaning to learning tasks so that such tasks would be perceived as useful in fulfilling future aspirations. Hence, students' future goals provide a driving force for their engagement in learning, including the use of deep learning (Andriessen, Phaet, & Lens, 2006; McInerney, Liem, Ortiga, Lee, & Manzano, 2008; Miller & Brickman, 2004). Based on the aforesaid studies, Liem et al. (2008) contend that future-oriented motivation is a proactive motive for learning rather than surface motive.

The future-oriented approach to learning consists of the learning strategy that exhorts students to learn beyond the minimum scope of study. As such, it is also related to the deep learning approach as depicted by the model in Fig. 5. This result is congruent with the findings by Fryer et al. (2012) and Wan Shahrazad Wan Sulaiman et al. (2013) where

the moderate positive relationship between deep approach and surface approach was found in the learning contexts of Japan and Malaysia. These results suggest that the scales of surface approach might be constituted differently in the Asian culture. It should be noted that the scales of the future-oriented approach in the present study, i.e. aim for qualification (Qlf) and minimising scope of study (Scp), are in fact the measuring scales for the surface approach originally. For Western students, intrinsic motivation is an antecedent for the adoption of deep learning strategies (Biggs, 1987a). However, Biggs and Watkins (1996) found that for students in the East, the adoption of deep strategies is stimulated by “a head of mixed motivational stem” (p. 273) which included many future concerns such as personal career, material reward, family reputation, in addition to genuine interest. Against the backdrop of an accounting learning context, the findings in this study indicate that accounting students have similar aspirations too. As Principles of Accounting is a fundamental course for the accounting profession, this subject directly motivates students to excel so as to enjoy brighter prospects in their future career (Department of Education, 2010; Turner, 2011).

Furthermore, besides a learning motive which concerns future goals, the learning strategy of learning beyond the minimum scope of study is also a reflection of the student's diligence, a value which is greatly emphasised in many Asian cultures. In addition to diligence, other learning virtues include endurance of hardship, humility, concentration, and perseverance (Rohlen & LeTendre, 1996; Salili, 1999). This is in contrast to Western cultures which attribute success to ability rather than effort (Holloway, 1988; Salili, Hwang, & Choi, 1989). Hence, the findings in this study lend support to previous studies that compare Western and Eastern cultures vis-à-vis learning virtues.

In short, the future-oriented approach to learning found in this study can be justified as an outcome influenced by the local social educational culture which envisages that exhorting effort in learning is a stepping stone that would lead to the realisation of aspirations.

ICT-supported learning environment perceptions

The construct of ICT-supported learning environment perceptions in the present study is characterised by ICT usage, student cohesiveness, cooperation, investigation, task orientation, teacher support, and involvement. The results of this study indicated that students' positive perceptions of their ICT-supported learning environment, which was in the context of accounting learning, contributed strongly to deep and future-oriented approaches to learning. Part of this finding is coherent with several studies which have found that accounting students who possess positive perceptions of their ICT-supported learning environments tend to adopt a deep approach to learning and are usually engaged in their learning (Arquero & Romero-Frias, 2013; Jebeile & Abeysekera, 2010; Turner, 2011).

Besides encouraging a deep approach to learning, the ICT-supported learning environment perceptions also contributed directly and unexpectedly to a new learning approach found in this study—future-oriented approach to learning. This finding suggests that students possess multiple motives for learning (Liem et al., 2008). They study Principles of Accounting not only because of intrinsic interest in the subject, which was reflected in their deep approach to learning in this study, but they also demonstrated

their commitment to learning Principles of Accounting so that they would acquire the requisite qualifications for brighter career prospects upon graduation. The learning environment supported by ICT could provide students an authentic learning experience and thus, encourage them to strive to become qualified accountants.

In addition, part of the perceptions of ICT-supported learning environment consisted of interrelated perceptions of cooperation, investigation, and student cohesiveness. Clearly, the use of ICT has to be integrated with a range of other learning experiences that develop interactive and cooperative learning as well as provide students the opportunity to take charge of investigation so that they are empowered in their own learning. This result is coherent with the notion propounded by some researchers that technology can be used appropriately as a pedagogical tool to enhance learning (Arquero & Romero-Frias, 2013; Hiralal, 2012; Jebeile & Abeysekera, 2010).

On the other hand, the interrelated perceptions of teacher support and involvement together with task orientation reveal that deep and future-oriented approaches to learning are encouraged when students feel involved and believe their teachers are supportive and give clear instructions on tasks or assignments. This result is echoed in few studies which found that students' perceptions of good teaching quality involve having reciprocal teacher-student relationship. Also, good teachers provide clear explanations, give helpful feedback, are committed to preparing helpful instructional materials, state clearly task requirements, and encourage students to do their best. Such positive attributes of teachers have a very strong impact on successful learning (Lillie & Wygal, 2011; Rumpagaporn, 2007).

In short, interactivity is important in the process of learning. Students are able to develop ideas, enquiries, and criticism through interaction; the perceived interactivity is a driver for adopting ICT in learning, ultimately leading to quality learning. Thus, the present study has shown the importance of the relationship between the construct of ICT-supported learning environment perceptions and the deep approach and moreover, the future-oriented approach to learning. In other words, incorporating ICT alone in the teaching and learning process may not enhance learning; ICT has to be used as a lever to promote student engagement so that it becomes a catalyst for effective learning.

Conclusion and implications

Overall, this study has proven that students' perceptions of an ICT-supported learning environment contribute to students' adoption of a deep approach and future-oriented approach to learning. The pedagogical approach that emphasises the use of ICT to enhance learning experience, rather than merely for the delivery of instruction, can contribute to successful learning.

The empirical results of this study have contributed to the SAL theory by the identification of a new learning approach, namely the future-oriented approach to learning. The finding takes cognizance of the influence of socio-cultural and educational contextual factors, while also taking into account learners' future goals and aspirations. Therefore, this finding enriches the body of knowledge and also cautions researchers against generalising by applying learning phenomena found in Western cultures to the Eastern context.

In addition, the direct and strong influence from the ICT-supported learning environment perceptions on deep and future-oriented approach to learning found in this study supports the 3Ps model (Ramsden, 2003), in particular the influence of perception of the learning environment on approaches to learning. It suggests that teachers should employ ICT as a pedagogical tool to foster students' deep learning. They should always reflect on employing a combination of teaching methods to create an engaging and constructive learning environment.

Abbreviations

AA: Academic ability; DA: Deep approach; DM: Deep motive; DS: Deep strategy; FA: Future-oriented approach; ISLEP: ICT-supported learning environment perceptions; PEE: Prior educational experience; Qlf: Aim for qualification; R-LPQ-2F: Revised Two-Factor Version of the Learning Process Questionnaire; SAL: Students' Approaches to Learning; SCCOIVG: Combination scales of Student Cohesiveness, Cooperation, and Investigation; Scp: Minimising scope of study; TO: Task orientation; TROFLE: Technology-Rich Outcomes-Focused Learning Environment Inventory; TSIVL: Combination scales of Teacher Support and Involvement

Acknowledgments

Not applicable.

Authors' contributions

SLW finalised the research objectives and research design of this study, while BST collected, analysed and interpreted the data. BST was the major contributor in writing the manuscript. All authors read and approved the final manuscript.

Funding

Not applicable.

Availability of data and materials

Not applicable.

Ethics approval and consent to participate

Not applicable.

Consent for publication

Not applicable.

Competing interests

The authors declare that they have no competing interests.

Received: 5 June 2019 Accepted: 18 February 2020

Published online: 25 May 2020

References

- Ainsworth, M. D. S., & Bowlby, J. (1991). An ethological approach to personality development. *American Psychologist*, 46, 331–341.
- Aldridge, J. M., Dorman, J. P., & Fraser, B. J. (2004). Use of multitrait-multimethod modelling to validate actual and preferred forms of the technology-rich outcomes-focused learning environment inventory (Troflei). *Australian Journal of Educational & Developmental Psychology*, 4, 110–125.
- Andriessen, I., Phalet, K., & Lens, W. (2006). Future goal setting, task motivation and learning of minority and non-minority students in Dutch schools. *British Journal of Educational Psychology*, 76, 827–850.
- Arquero, J. L., & Romero-Frias, E. (2013). Using social network sites in higher education: An experience in business studies. *Innovations in Education and Teaching International*, 50(3), 238–249.
- Biggs, J. B. (1985). The role of meta-learning in study process. *British Journal of Educational Psychology*, 55, 185–212.
- Biggs, J. B. (1987a). *Student approaches to learning and studying*. Hawthorn: Australian Council for Educational Research.
- Biggs, J. B. (1987b). *Study process questionnaire manual*. Hawthorn: Australian Council for Educational Research.
- Biggs, J. B. (1987c). *The learning process questionnaire manual*. Hawthorn: Australian Council for Educational Research.
- Biggs, J. B. (1993). What do inventories of students' learning process really measure? A theoretical review and clarification. *British Journal of Educational Psychology*, 83, 3–19.
- Biggs, J. B. (1999). *Teaching for quality learning at university*. Buckingham: Society for Research into Higher Education.
- Biggs, J. B., Kember, D., & Leung, D. Y. P. (2001). The revised study process questionnaire. *British Journal of Educational Psychology*, 71, 133–149.
- Biggs, J. B., & Moore, P. J. (1993). *The process of learning* (3rd ed.). New York: Prentice Hall.
- Biggs, J. B., & Watkins, D. (1996). The Chinese learner in retrospect. In D. Watkins & J. B. Biggs (Eds.), *The Chinese learner: Cultural, psychological and contextual influences* (pp. 269–285). Hong Kong/ Melbourne: Comparative Education Research Centre, University of Hong Kong/ Australian Council for Educational Research.
- Bloom, B. S. (1976). *Human characteristics and school learning*. New York: McGraw-Hill.
- Booth, P., Lockett, P., & Mladenovic, R. (1999). The quality of learning in accounting education: The impact of approaches to learning on academic performance. *Accounting Education: An International Journal*, 8, 277–300.

- Borthick, A. F., & Clark, R. L. (1986). The role of productive thinking in affecting student learning with microcomputers in accounting education. *The Accounting Review*, *LXI*(1), 143–157.
- Buhs, E., Ladd, G., & Herald, S. (2006). Peer exclusion and victimization processes that mediate the relation between peer group rejection and children's classroom engagement and achievement. *Journal of Educational Psychology*, *98*, 1–13.
- Child, D. (1990). *The essentials of factor analysis* (2nd ed.). London: Cassel Educational.
- Costello, A. B., & Osborne, J. W. (2005). Best practices in exploratory factor analysis: Four recommendations for getting the most from your data analysis. *Practical Assessment Research & Evaluation*, *10*(7), 1–9.
- DeCoster, J. (1998). Overview of factor analysis. <http://www.stat-help.com/notes.html>. Retrieved 14 Aug 2015.
- Department of Education. (2010). *Whole school evaluation: Evaluation guidelines and criteria*. Pretoria: Government Printer.
- DeVellis, R. F. (2003). *Scale development: Theory and applications* (2nd ed.). Thousand Oaks: Sage Publications.
- DeVolder, M. L., & Lens, W. (1982). Academic achievement and future time perspective as a cognitive-motivational concept. *Journal of Personality and Social Psychology*, *42*, 566–571.
- Dull, R. B., Schleifer, L. F., & McMillan, J. J. (2015). Achievement goal theory: The relationship of accounting students' goal orientations with self-efficacy, anxiety, and achievement. *Accounting Education: An International Journal*, *24*(2), 152–174.
- Duman, H., Apak, I., Yucenursen, M., & Peker, A. A. (2014). Determining the anxieties of accounting education students: A sample of Aksaray University. *Procedia – Social and Behavioral Sciences*, *174*, 1834–1840.
- Eley, M. G. (1992). Differential adoption of study approaches within individual students. *Higher Education*, *23*, 231–254.
- Fryer, L. K., Ginns, P., Walker, R. W., & Nakao, K. (2012). The adaptation and validation of the CEQ and the R-SPQ-2F to the Japanese tertiary environment. *British Journal of Educational Psychology*, *82*, 549–563.
- Hair, J. F., Jr., Black, W. C., Babin, B. J., Anderson, R. E., & Tatham, R. L. (2006). *Multivariate data analysis* (6th ed.). Upper Saddle River: Prentice Hall, Pearson Education.
- Hamre, B., & Pianta, R. (2001). Early teacher-child relationships and the trajectory of children's school outcomes through the eighth grade. *Child Development*, *72*, 625–638.
- Harada, V. H. (2003). From instruction to construction: Learning in the information age. In M. Fitzgerald, M. Orey, & R. M. Branch (Eds.), *Educational media and technology year book 2003* (pp. 40–48). Westport: Libraries Unlimited.
- Hiralaal, A. (2012). Students' experiences of blended learning in accounting education at the Durban University of Technology. *South African Journal of Higher Education*, *26*(2), 316–328.
- Holcomb, T., Ireland, R., Holmes, R., & Hitt, M. (2009). Architecture of entrepreneurial learning: Exploring the link among heuristics, knowledge, and action. *Entrepreneurship Theory and Practice*, *33*(1), 167–192.
- Holloway, S. D. (1988). Concepts of ability and effort in Japan and the US. *Review of Educational Research*, *58*, 327–345.
- Immekus, J. C., & Imbrie, P. K. (2010). A test and cross-validation of the revised two-factor study process questionnaire factor structure among western university students. *Educational and Psychological Measurement*, *70*, 495–510.
- Jackling, B. (2005). Perceptions of the learning context and learning approaches: Implications for quality learning outcomes in accounting. *Accounting Education*, *14*(3), 271–291.
- Jebeile, S., & Abeysekera, I. (2010). The spread of ICT innovation in accounting education. *International Journal of Teaching and Learning in Higher Education*, *22*(2), 158–168.
- Kember, D., Biggs, J. B., & Leung, D. Y. P. (2004). Examining the multidimensionality of approaches to learning through the development of a revised version of the learning process questionnaire. *British Journal of Educational Psychology*, *74*, 261–280.
- Kozma, R. B. (1991). Learning with media. In *Review of Educational Research (Summer)* (pp. 179–211).
- Liem, A. D., Nair, E., Bernardo, A. B. I., & Prasetya, P. H. (2008). In the students' own words: Etic and emic conceptual analyses of why and how students learning. In O. S. Tan, D. M. McInerney, A. D. Liem, & A. G. Tan (Eds.), *What the west can learn from the east: Asian perspectives on the psychology of learning and motivation* (pp. 137–168). North Carolina: Information Age Publishing.
- Lillie, R. E., & Wygal, D. E. (2011). Virtual office hours (VOH) in accounting coursework: Leveraging technology to enhance an integrative learning environment. *Journal of Accounting Education*, *29*, 1–13.
- Lirn, T.-C., Lin, H.-W., & Shang, K.-C. (2014). Green shipping management capability and firm performance in the container shipping industry. *Maritime Policy & Management*, *41*(2), 159–175.
- Little, T. D., Cunningham, W. A., Shahar, G., & Widaman, K. F. (2002). To parcel or not to parcel: Exploring the question, weighing the merits. *Structural Equation Modeling*, *9*(2), 151–173.
- Lucas, U. (2000). Worlds apart: Students' experiences of learning introductory accounting. *Critical Perspectives on Accounting*, *11*, 479–504.
- MacCallum, R. C., Widaman, K. F., Zhang, S., & Hong, S. (1999). Sample size in factor analysis. *Psychological Methods*, *4*, 84–99.
- Martinelli, V., & Raykov, M. (2017). Evaluation of revised two-factor study process questionnaire (R-SPQ-2F) for student teacher approaches to learning. *Journal of Educational and Social Research*, *7*(2), 9–13.
- Marton, F., & Säljö, R. (1976). On qualitative differences in learning: II. Outcome as a function of the learner's conception of the task. *British Journal of Educational Psychology*, *46*, 115–127.
- Marton, F., & Säljö, R. (1984). Approaches to learning. In F. Marton, D. J. Hounsell, & N. J. Entwistle (Eds.), *The experience of learning* (pp. 36–55). Edinburgh: Scottish Academic Press.
- McInerney, D. M., Liem, A. D., Ortega, Y. P. Y., Lee, J. Q., & Manzano, A. S. (2008). Future goals and self-regulated learning among Singaporean Chinese students: The mediating role of the utility values of schooling, academic self-concept, and academic motivation. In O. S. Tan, D. M. McInerney, A. D. Liem, & A. G. Tan (Eds.), *What the west can learn from the east: Asian perspectives on the psychology of learning and motivation* (pp. 267–293). North Carolina: Information Age Publishing.
- Miller, R. B., & Brickman, S. J. (2004). A model of future-oriented motivation and self-regulation. *Educational Psychology Review*, *16*, 9–33.
- Ministry of Education. (2006). *Rancangan Malaysia Ke-9: Pelan Induk Pembangunan Pendidikan, 2006–2010 [Ninth Malaysia Plan: Blueprint of Education Development, 2006–2010]*. Putrajaya: Author.
- Nadzrah, A. B. (2007). Factors that contribute to the effective use of computers in the classroom: The Malaysian context. *Asiacall Online Journal*, *2*(1), 27–33. http://asiacall.org/journals/journal_articles_2006_2007/NadzrahRevision01.pdf. Retrieved 6 June 2014.
- Pittaway, L., & Cope, J. (2007). Entrepreneurship education. *International Small Business Journal*, *25*(5), 479–510.

- Prensky, M. (2001). Digital natives, digital immigrants. *On the Horizon*, 9(5), 1–6.
- Ramsden, P. (2003). *Learning to teach in higher education* (2nd ed.). London: Routledge.
- Richardson, J. T. E. (1994). Cultural specificity of approaches to studying in higher education: A literature survey. *Higher Education*, 27, 449–468.
- Rohlen, T. P., & LeTendre, G. K. (1996). Conclusion: Themes in the Japanese culture of learning. In T. P. Rohlen & G. K. LeTendre (Eds.), *Teaching and learning in Japan* (pp. 369–376). Cambridge: Cambridge University Press.
- Rumpagaporn, M. W. (2007). Students' critical thinking skills, attitude to ICT and perceptions of ICT classroom learning environments under the ICT schools pilot project in Thailand. (Doctoral dissertation, University of Adelaide, Australia). <http://digital.library.adelaide.edu.au/dspace/bitstream/2440/37896/1/02whole.pdf>. Retrieved 3 May 2012.
- Salili, F. (1999). Accepting personal responsibility for learning. In D. A. Watkins & J. B. Biggs (Eds.), *The Chinese learner: Cultural, psychological and contextual influences* (pp. 85–105). Hong Kong/ Melbourne: Comparative Education research Centre, University of Hong Kong/ Australian Council for Educational Research.
- Salili, F., Hwang, C. E., & Choi, N. F. (1989). Teachers' evaluative behavior: The relationship between teachers' comments and perceived ability in Hong Kong. *Journal of Cross-Cultural Psychology*, 20, 115–132.
- Sharan, S. (1995). Group investigation theoretical foundations. In J. E. Pedersen & A. D. Digby (Eds.), *Secondary schools and cooperative learning* (pp. 251–277). New York: Garland.
- Sharan, Y., & Sharan, S. (1992). *Expanding cooperative learning through group investigation*. New York: Teachers College Press.
- Sharma, D. (1997). Accounting students' learning conceptions, approaches to learning, and the influence of the learning-teaching context on approaches to learning. *Accounting Education: An International Journal*, 6(2), 125–146.
- Simons, J., Vansteenkiste, M., & Lens, W. (2004). Placing motivation and future time perspective theory in a temporal perspective. *Educational Psychology Review*, 16, 121–139.
- Slavin, R. E. (1995). *Cooperative learning: Theory, research, and practice* (2nd ed.). Boston: Allyn and Bacon.
- Smart School Project Team. (1997). *The Malaysian smart schools: Implementation plan*. Kuala Lumpur: Ministry of Education Malaysia.
- Sukumaran, S. (1991). *Strategi pengajaran simpan kira dan perakaunan KBSM [Teaching strategy for book-keeping and accounting of integrated secondary school curriculum]*. Petaling Jaya: Fajar Bakti.
- Wan Shahrazad Wan Sulaiman, Wan Rafei Abdul Rahman, Mariam Adawiah Dzulkifli, & Wan Samhanin Wan Sulaiman (2013). Reliability of second-order factor of a revised two-factor study process questionnaire (R-SPQ-2F) among university students in Malaysia. *ASEAN Journal of Teaching and Learning in Higher Education*, 5(2), 1–13.
- Technical Education Department. (2000). *Huraian sukatan pelajaran Kurikulum Bersepadu Sekolah Menengah: Prinsip Perakaunan Tingkatan 4 dan 5 [Curriculum specifications for integrated secondary school curriculum: Principles of accounting form 4 and 5]*. Kuala Lumpur: Author, Ministry of Education Malaysia.
- The Purpose of Accounting Education. (2016). In M. E. Persson (Ed.), *Littleton's final thoughts on accounting: A collection of unpublished essays* (pp. 47–55). Bradford: Emerald.
- Tourism Malaysia. (2013). *Malaysia travel guide: Visit Malaysia 2014*. Putrajaya: Tourism Malaysia, Ministry of Tourism.
- Turner, M. C. (2011). *A method and resources to support accounting students to think critically*. New Zealand: Ako Aotearoa.
- United Nations Educational, Science and Cultural Organization. (2012). *Malaysia education policy review*. Paris: Author.
- United Nations Educational, Science and Cultural Organization. (2015). *Education for all 2015 national review report: Malaysia*. Paris: Author <http://unesdoc.unesco.org/images/0022/002297/229719E.pdf>. Retrieved 27 Mar 2017.
- Wentzel, K. R. (2004). Understanding classroom competence: The role of social-motivational and self-processes. In R. Kail (Ed.), *Advances in child development and behavior* (Vol. 32, pp. 213–241). New York: Elsevier.
- Wentzel, K. R. (2009). Students' relationships with teachers as motivational contexts. In K. R. Wentzel & A. Wigfield (Eds.), *Handbook of motivation at school* (pp. 301–322). Mahwah: LEA.

Publisher's Note

Springer Nature remains neutral with regard to jurisdictional claims in published maps and institutional affiliations.

Submit your manuscript to a SpringerOpen[®] journal and benefit from:

- Convenient online submission
- Rigorous peer review
- Open access: articles freely available online
- High visibility within the field
- Retaining the copyright to your article

Submit your next manuscript at ► [springeropen.com](https://www.springeropen.com)
